



景天灯具制造（上海）有限公司  
Gemstone Lighting(Shanghai)co.,ltd

## CL4512 Floodlight Series



Keep glare away from equipment lighting areas

# CL4512 Floodlight Series



## Model Description

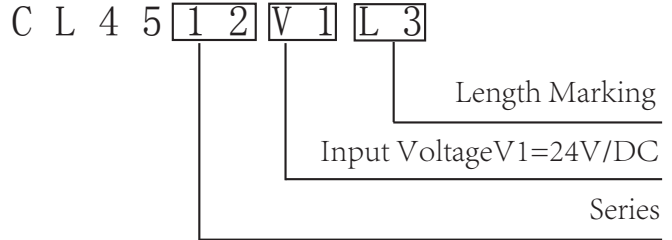

## Application Scenarios

- \*Precision Large & Medium Machining
- \*Centers
- \*Semiconductor Industry
- \*Automation Industry
- \*Robot Auxiliary Lighting

Sturdy

Low Power

High

IP 67

Anti-glare

waterproof

## Specifications / Model

Model	Voltage	Power	IP Rating	Cable
CL45112V1L3	24V/DC	24W	IP67	Standard cable length: 1.5m

## Mounting Dimensions/mm

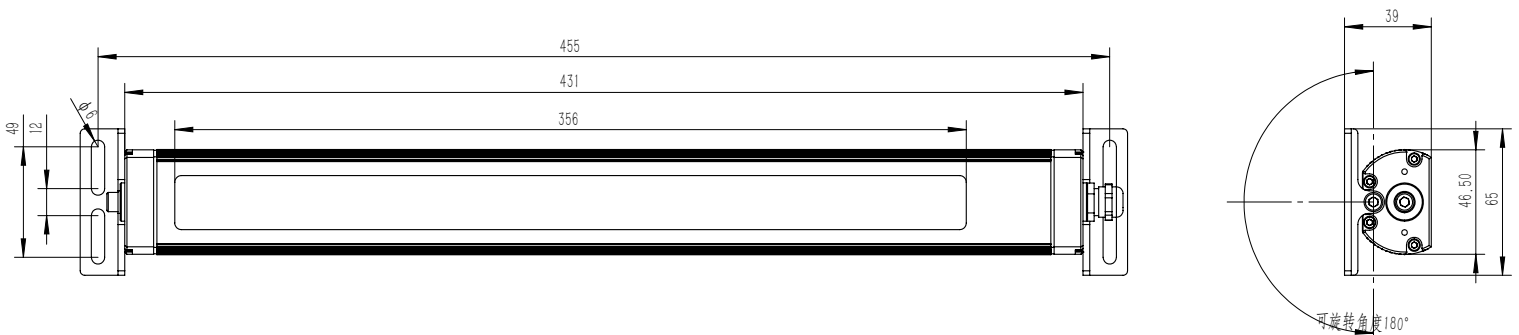

# CL4512 Floodlight Series

## Lamp Appearance



## Lamp Parameters

Driver	Voltage Range	LED Brand	CT	RA	Housing Material	Surface Process
Constat current	18-36V/DC	SAMSUNG	5700K	Ra>85	6061 Aluminum	Anodizing

## Installation Guide

### Wiring Method



24V DC wiring no positive and negative distinction

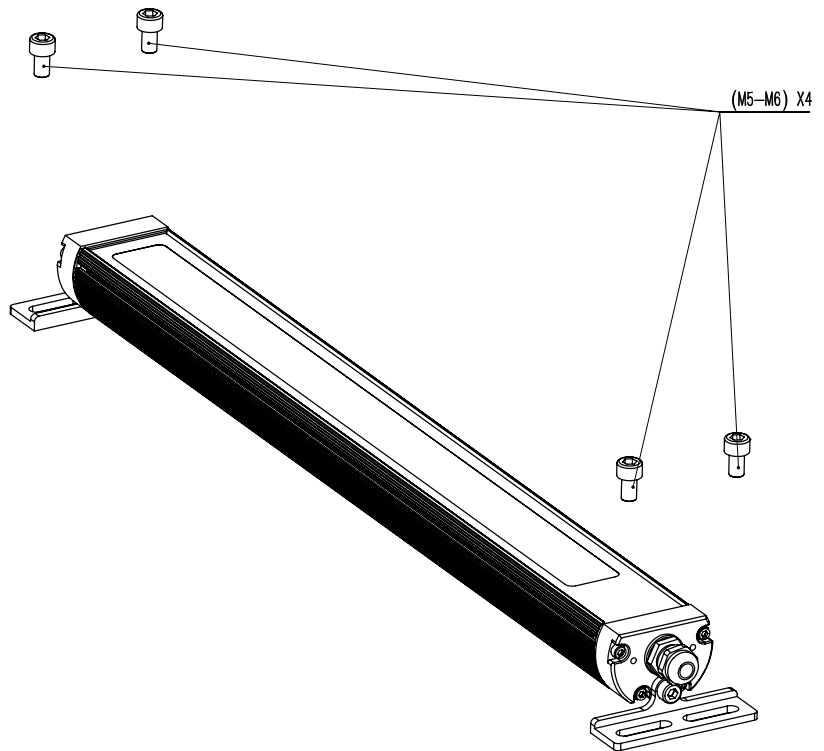

## Contact us



Gemstone Lighting(Shanghai)Co.,LTD

T L : + 8 6 1 8 6 2 1 9 5 2 8 1

E Mail: info@gemstonelighting.com

website : www.gemstonelighting.com

Sales office Room 606, Building 6, No.258 Songmin Road, Songjiang District, Shanghai

Production Base: No.168 Xinyang Road, Mengzhuang Town, Huixian City, Henan Province